



High Speed CF card

Specification



Workshop NO.16,7/F,Po Hing Centre,

18 Wang Chiu Road,KowloonBay

九龙湾宏照道 18 号宝兴中心 7/F 709 室

Tel +852 2344 9422

Fax +852 2344 9432

High speed CF card Specification

Proprietary & Confidential

Copyright 2006

General Description

SM222 is the 3rd generation CompactFlash controller of Silicon Motion, Inc., which use 0.18 um process technology. It has higher performance, lower power consumption. SM222 supports CompactFlash specification revision 3.0 except UltraDMA mode. SM222 has dual channels 8bit or single channel 16bit high speed flash interface with RS-ECC, and support all kinds of NAND type flash. Include MLC, SLC, AG-AND flash memory.

The following figure is the typical application block diagram of SM222.

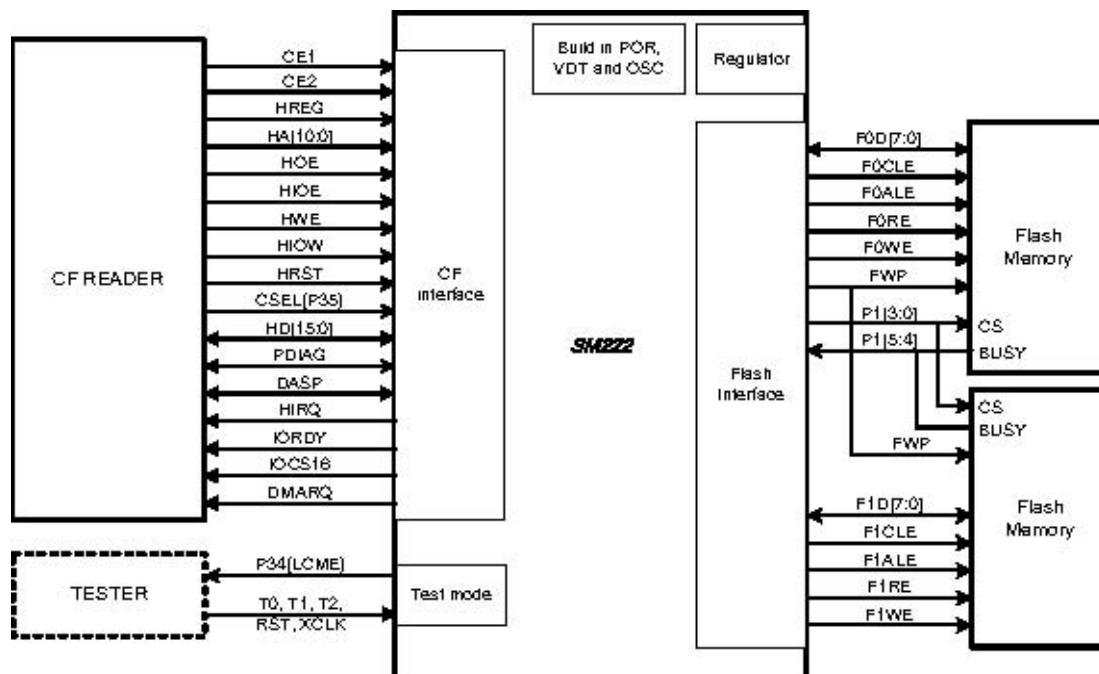

Figure 2 SM222 application block diagram.

Power System of SM222

SM222 has the following 3 power supply groups:

(1) VCCK :

kernel power supply. Input range is 1.65~1.95V. Supplied by the build in voltage regulator whose output pin is VD18. The supply current is 100 mA. An 1uF capacitance is recommended to be connected between pin“VD18” and ground to stabilize the current supply.

(2) VCC3 :

input/output reference for system and flash interface I/O. Supply range is 2.7~3.6V. An 1uF capacitance is

recommended to be connected between pin “VD33” and ground to stabilize the power supply.

(3) VCC35 :

input/output reference for CompactFlash interface I/O. Supply range is 3.0~5.5V. A 1uF capacitance is recommended to be connected between pin “VCC35” and ground to stabilize the power supply.

Pin Function definition

Flash Interface

Pin Name	Dir	TQFP128	BGA84	Description
F0D[7:0]	I/O	72-77 79-80	E9, E10, F9,F10, F10, G8-G10,	8 bit : Flash0 interface data bus, direct connect to the flash memory. 16 bit : Flash interface data bus low byte, direct connect to the flash memory.
F0CLE	O	81	E8	Flash0 interface command latch enable, direct connect to the flash memory.
F0ALE	O	82	D10	Flash0 interface address latch enable, direct connect to the flash memory.
F0RE	O	83	D9	Flash0 interface read strobe control, direct connect to the flash memory.
F0WE	O	84	D8	Flash0 interface write strobe control, direct connect to the flash memory.
F1D[7:0]	I/O	51-54 56-59	H4,H6 J4-J6 K3-K4	8 bit : Flash1 interface data bus, direct connect to the flash memory. 16 bit : Flash interface data bus high byte, direct connect to the flash memory.
F1CLE	O	63	H7	8 bit : Flash1 interface command latch enable, direct connect to the flash memory. 16 bit : NC
F1ALE	O	62	J7	8 bit : Flash1 interface address latch enable, direct connect to the flash memory. 16 bit : NC
F1RE	O	61	K7	8 bit : Flash1 interface read strobe control, direct connect to the flash memory. 16 bit : NC
F1WE	O	60	K6	8 bit : Flash1 interface write strobe control, direct connect to the flash memory. 16 bit : NC
FWP	O	65	G7	Flash interface write protection, direct connect to the flash memory.
P1[3:0]	O	67,68, 70,71	K9,H8, H9,J10	Used as flash chip select signal. Max. 4 flash chips can connect to SM222.
P1[5:4]	I	66,69	J8,J9	Used as busy signal from flash memory.
VCC3	Power in	128	H5	Power supply for flash group I/O pad.

CompactFlash Interface

Pin Name	Dir	TQFP128	BGA84	Description
CE1	I	22	C2	CompactFlash interface chip select signal
CE2	I	21	B1	CompactFlash interface chip select signal
HREG	I	99	A6	CompactFlash interface control signal
HA[10:0]	I	34,37,39, 41,43,45, 46,98,100 102,106,	A5,B6, D7,	CompactFlash interface address

HOE	I	35	G3	CompactFlash interface output enable
HIOE	I	36	G4	CompactFlash interface I/O output enable

HWE	I	40		CompactFlash interface write enable
HIOW	I	36	H1	CompactFlash interface I/O write enable
CSEL(P35)	I	44		CompactFlash interface master/slaver control signal
HRST	I	107	A4	CompactFlash interface reset signal
HD[15:0]	I/O	23-32 89,87 91-93 95	A7,A9,B8, B9,C8,C9 ,D1-D3, F1-F3,E1E3	CompactFlash interface data bus
PDIAG	I/O	94	A8	CompactFlash interface master/slaver handshake signal
DASP	I/O	96	B7	CompactFlash interface master/slaver handshake signal
HIRQ	O	42	H2	CompactFlash interface interrupt signal
IORDY	O	105	C5	CompactFlash interface wait state signal
IOCS16	O	88	B10	CompactFlash interface data bus width status
DMARQ	O	101	C6	CompactFlash interface DMA request signal
VCC35	Power in	90	C7	Power supply for CompactFlash interface group I/O pad.

System Configuration Pins

Pin Name	Dir	TQFP128	BGA84	Description
P16	I	49	K2	Reserved
P17	O	50	J3	Hardware Pre-Test.

Test Pins

Pin Name	Dir	TQFP128	BGA84	Description
T2	I	114	B3	Test mode selection, tie to low for normal operation.
T1	I	115	A2	Test mode selection, tie to low for normal operation.
T0	I	116		Test mode selection, tie to low for normal operation.
RST, XCLK	I	113,111	A3,D4	Reserved for CP/FT. tie to high for normal operation.
P34	I/O	64		Reserved for debug. floating for normal operation.
XROMA[14:0]	O	1-5, 117-127		External ROM address line.
XROMD[7:0]	I	9-16		External ROM data line.
LDE	I	18		Reserved for debug, tie to low for normal operation.
XRAMOE	O	7		Reserved for debug, floating for normal operation.
XRAMWE	O	8		Reserved for debug, floating for normal operation.
XRAMCS	O	6		Reserved for debug, floating for normal operation.
XROME	I	17		Reserved for debug, tie to low for normal operation.

Voltage Regulator

Pin Name	Dir	TQFP128	BGA84	Description
VD18	Power out	109	C4	1.8V / 100 mA power supply.
VD33	Power in	110	B4	Regulator in. Direct connect to card source power.
VSSA	Ground	108		Analog ground.

Other Power Pins

Pin Name	Dir	TQFP128	BGA84	Description
VCCK	Power in	103	C10	SM222 kernel power supply. 1.8V input.

No.	Name	No.	Name	No.	Name	No.	Name
	XROMA11	33	VCC35	65	FWP	97	VCC35
	XROMA12	34	HA10	66	P14	98	HA0
	XROMA13	35	HOE	67	P11	99	HREG
	XROMA14	36	HIOE	68	P10	100	HA1
	XROMA15	37	HA9	69	P15	101	DMARQ
	XROMCS	38	HIOW	70	P12	102	HA2
	XRAMOE	39	HA8	71	P13	103	VCCK
	XRAMWE	40	HWE	72	F0D0	104	GND
	XROMD0	41	HA7	73	F0D1	105	IORDY
	XROMD1	42	HIRQ	74	F0D2	106	HA3
	XROMD2	43	HA6	75	F0D3	107	HRST
	XROMD3	44	P35	76	F0D4	108	VSSA
	XROMD4	45	HA5	77	F0D5	109	VD18
	XROMD5	46	HA4	78	VCC3	110	VD33
	XROMD6	47	VCCK	79	F0D6	111	XCLK
	XROMD7	48	GND	80	F0D7	112	GND
	XROME	49	P16	81	F0CLE	113	RST
	LDE	50	P17	82	F0ALE	114	T2
	GND	51	F1D0	83	F0RE	115	T1
	VCCK	52	F1D1	84	F0WE	116	T0
	CE2	53	F1D2	85	VCCK	117	XROMA0
	CE1	54	F1D3	86	GND	118	XROMA1
	HD15	55	VCC3	87	HD10	119	XROMA2
	HD7	56	F1D4	88	IOCS16	120	XROMA3
	HD14	57	F1D5	89	HD9	121	XROMA4
	HD6	58	F1D6	90	VCC35	122	XROMA5
	HD13	59	F1D7	91	HD2	123	XROMA6
	HD5	60	F1WE	92	HD8	124	XROMA7
	HD12	61	F1RE	93	HD1	125	XROMA8

	HD4	62	F1ALE	94	PDIAG	126	XROMA9
	HD11	63	F1CLE	95	HD0	127	XROMA10
	HD3	64	P34	96	DASP	128	VCC3

General DC Characteristics CompactFlash

interface I/O at 5.0V

Parameter	Symbol	Min.	Max.	Unit	Remark
Supply Voltage	V _{CC}	4.5	5.5	V	
High level output voltage	V _{OH}	V _{CC} -0.8		V	
Low level output voltage	V _{OL}		0.8	V	
High level input voltage	V _{IH}	4.0		V	Non-schmitt trigger
		2.6	3.04	V	Schmitt trigger ₁
Low level input voltage	V _{IL}		0.8	V	Non-schmitt trigger
		1.53	1.79	V	Schmitt trigger ₁
Pull up resistance ₂	R _{PU}	52.54	86.56	kOhm	
Pull down resistance	R _{PD}	63	244	kOhm	

CompactFlash interface I/O at 3.3V

Parameter	Symbol	Min.	Max.	Unit	Remark
Supply Voltage	V _{CC}	2.97	3.63	V	
High level output voltage	V _{OH}	V _{CC} -0.8		V	
Low level output voltage	V _{OL}		0.8	V	
High level input voltage	V _{IH}	2.4		V	Non-schmitt trigger
		1.67	1.88	V	Schmitt trigger ₁
Low level input voltage	V _{IL}		0.6	V	Non-schmitt trigger
		0.92	1.07	V	Schmitt trigger ₁
Pull up resistance ₂	R _{PU}	81.39	154.85	kOhm	
Pull down resistance	R _{PD}	42	172	kOhm	

The I/O pins other than CompactFlash interface

Parameter	Symbol	Min.	Max.	Unit	Remark
Supply Voltage	V _{CC}	2.7	3.6	V	
High level output voltage	V _{OH}	2.4		V	
Low level output voltage	V _{OL}		0.4	V	
High level input voltage	V _{IH}	2.0		V	Non-schmitt trigger
		1.4	2.0	V	Schmitt trigger ³
Low level input voltage	V _{IL}		0.8	V	Non-schmitt trigger
		0.8	1.2	V	Schmitt trigger ³
Pull up resistance ⁴	R _{PU}	40		kOhm	
Pull down resistances	R _{PD}	40		kOhm	

- 1 Include CE1, CE2, HREG, HOE, HIOE, HWE, HIOW pins.
- 2 Include CE1, CE2, HREG, HOE, HIOE, HWE, HIOW, CSEL(P35), PDIAG, DASP pins.
- 3 Include XROME, LDE, RST, T0, T1, T2 pins.
- 4 Include RST, XROMCS, XRAMOE, XRAMWE, P14, P15, P16, P17, P34 pins.
- 5 Include XROME, LDE, T0, T1, T2, XROMA, XROMD pins.

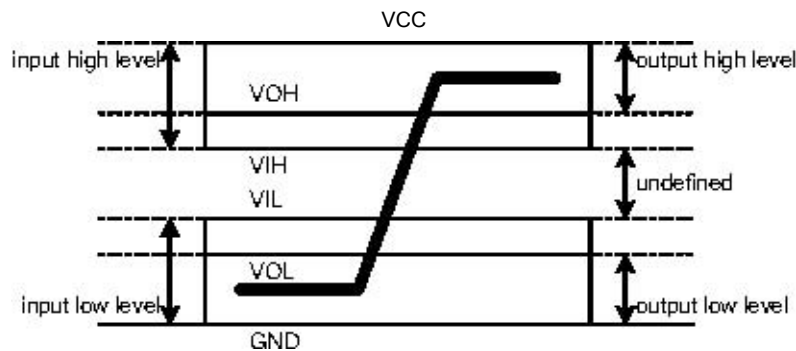
Power Consumption

Parameter	Typ.	Unit	Remark
Read current at 3.3V	15.57	mA	V _{DD} = 3.3V
Write current at 3.3V	15.76	mA	V _{DD} = 3.3V
Standby current at 3.3V	0.46	mA	V _{DD} = 3.3V
Read current at 5.0V	11.58	mA	V _{DD} = 5.0V
Write current at 5.0V	9.59	mA	V _{DD} = 5.0V
Standby current at 5.0V	0.5	mA	V _{DD} = 5.0V

